

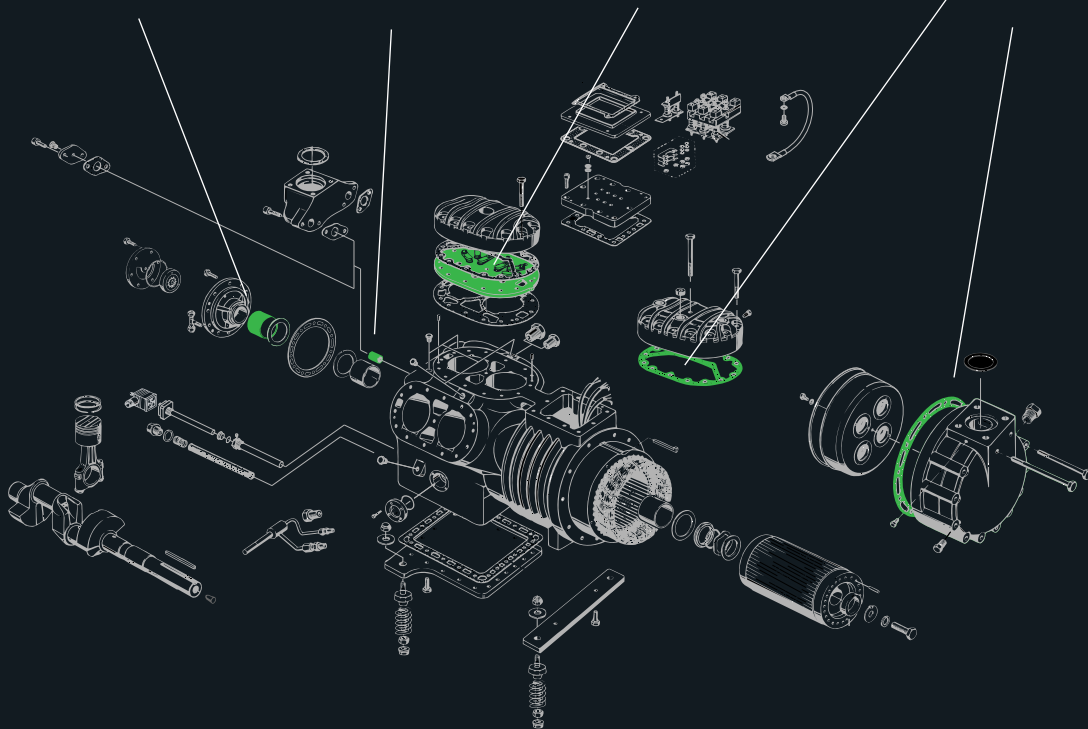

ORIGINAL SPARE PARTS THE RIGHT CHOICE



WHAT ARE BITZER ORIGINAL SPARE PARTS?

“Original spare parts” identifies all the components inside a BITZER compressor, from the most important and critical mechanical part to the smallest screw, which pass the demanding quality standard of BITZER. Original spare parts are supplied only through the BITZER distribution network and the Green Point network. BITZER has studied, designed, tested and specified every single detail of each part. In a demanding environment, like the nowadays market, where energy efficiency is always in the front line of the requirements, the original spare parts guarantee the optimized efficiency of the compressor. Every part in the end contributes to optimize performances, decrease noise level, reduce power consumption and improve the reliability and the life expectation of your compressor.



WHAT'S DIFFERENT BETWEEN ORIGINAL SPARE PARTS AND COPIES?

Deeper analysis and comparison over some key components offer the evidence of the benefits that you, as a customer, can expect by doing the right choice in using BITZER original spare parts when repairing your BITZER compressor.

QUALITY KIT: THE COMPLETE SOLUTION TO GUARANTEE THE SAFE AND RELIABLE OPERATION OF YOUR COMPRESSOR



Green Point Quality Kit: State of Art repair goes together with BITZER original spares.

After Green Point offers the market a high-quality service, BITZER now goes one step further. Green Point Quality Kits provide complete, easy, and competitive solutions to guarantee customers reliable servicing for their compressors.

The combination of parts included in the Quality Kit has been carefully selected by BITZER in order to ensure the reestablishment of the best performances and the safety of the operations.

All the components will be replaced unconditionally in each compressor overhauled by Green Point, leaving no space for potential failures due to any kind of misjudgment of the status of each part.

Clients are always the focus of BITZER and Green Point attention and the Quality Kits are the new answer to the market demands for professional service.

BITZER ORIGINAL SPARE PARTS: SMALL DETAILS MAKE BIG DIFFERENCE IN RELIABILITY AND PERFORMANCE.



PISTONS AND CONNECTING RODS

Original BITZER Pistons

1a Dimensions and finish of pistons have tight tolerances to guarantee optimized efficiency.

2a Piston material quality with no pores to guarantee greater resistance.

3a High surface finish and customized shape of suction valve seats to minimize the effects of dead space.

4a PTFE thrust washer between connecting rod and piston to obtain optimized axial clearance.

5a Small eye of connecting rod fitted with bearing bush to improve resistance at high loads.

BEARINGS

Original BITZER Bearings

6a Bearing bushes provided with antiwear coating for longer life and higher resistance to operating loads.

7a Open gap of bushes to ensure perfect fit when assembled in compressor housing.

Non-Original Pistons

1b Poor finish and non-optimized diameters of pistons. Different diameters at piston top and bottom may lead to reduced volumetric efficiency, resulting in lower cooling capacity.

2b Piston material with high porosity are potentially dangerous and may compromise material resistance.

3b Approximate design of suction valve seats not optimized to specific compressor model.

4b Absence of thrust washer leads to increased noise and potentially negative impacts on cylinder bores and also on motor.

5b Absence of bush may result in excessive wear due to loads during operation.

Non-Original Bearings

6b Bronze bushes are frequently used and are not suitable for tough operating conditions.

7b Grooved notch may lead to incorrect dimensions after installation or may deform bush. Risk of shaft seizure.

GASKETS

Original BITZER Gaskets

8a Optimized selection of gasket material for better compatibility with all refrigerants and lubricants.

Consistent behavior of gaskets across entire operating range of compressors. No swelling of sealing material due to temperature fluctuations and no leakage due to gasket porosity.

Controlled thickness on suction side of valve plate optimizes dead space of compressor.

9a Systematic use of metallic gaskets on high-pressure side to guarantee better resistance under tough operating conditions.

Non-Original Gaskets

8b Non-original gaskets often made of asbestos which has been banned from the market since 1995.

All counterfeit gaskets are generally made of soft material and have rough surfaces which do not ensure proper tightness.

Gasket thickness often up to 30% greater than original gaskets, with negative impact on compressor performance due to increased dead space.

9b Soft gaskets on both suction and discharge sides of compressor may result in damage during operation at high pressure ratios.

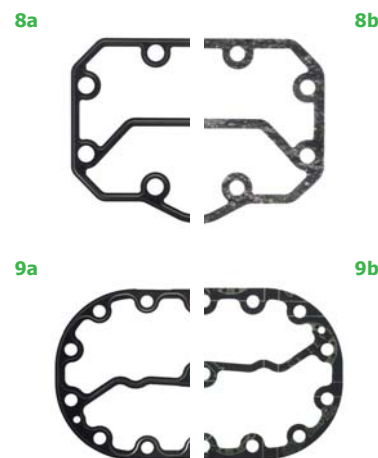

VALVE PLATES AND REED VALVES

Original BITZER Valve Plates

10a Clean machining and assembly of valves to improve tightness and performance.

11a Discharge holes with pressed valve seat to improve tightness.

Suction reeds with clean finish and star-centered cut to guarantee correct design.

13a Discharge reed stopper with optimized stroke across full operating range.

Non-Original Valve Plates

10b Poor machining and finish, especially on valve seats, may lead to leakage during operation.

11b Sharp valve seat edges and poor finish affect leakage rates through valves.

12b Poor cut finish on suction reeds may result in shorter valve service life. Every edge leads to additional mechanical stress.

13b Discharge stopper with max. 1 mm shorter stroke leads to incorrect functioning of discharge reed.

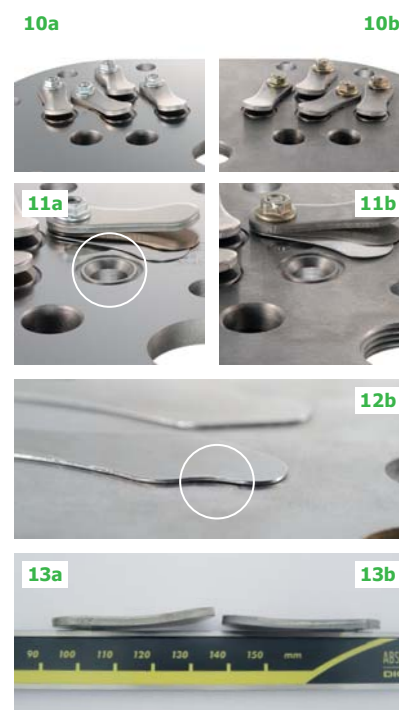

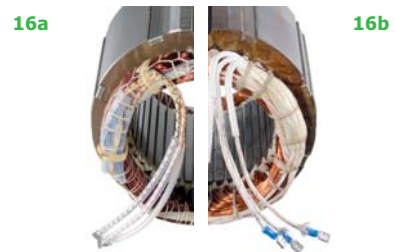
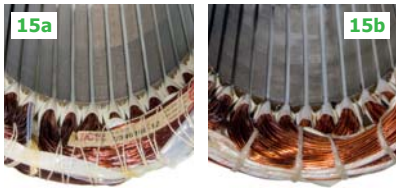

ELECTRIC MOTORS

Original BITZER Motors

14a Guaranteed copper quality, insulation materials and execution.

15a Rated electrical specifications of motor on label affixed to winding, international certificates, and safety commitment.

16a PTC temperature sensors installed in windings provide thermal protection.

Rewound Motors

14b Potential high vibrations in coils due to poor quality during rewinding process. Risk of spot burn damage in coils.

15b Absence of label with electrical ratings may lead to operation outside of motor limits. No certification or commitment to safety regulations.

16b Absence of temperature sensors for protection against winding overheating.

HOW NON-ORIGINAL SPARE PARTS PERFORM

All the specifications for original spare parts are defined after numerous tests in the BITZER laboratories. Performance is then confirmed by tests to which every compressor is subjected at the end of the production line.

BITZER defines tolerances for leakage limits, electrical parameters, and performance ratings based on strict regulations. Non-original parts are tested and the results are compared to original parts. They show lower overall quality and performance.

ELECTRIC MOTOR TEST

Comparison Test

Original Electric Motor

Rewound Motors

Resistance across single phase

0.879 Ω

0.525 Ω

17a/17b

Resistance across group of cables

1.759 Ω

1.056 Ω

18a/18b

High-voltage test to test current leakage (approx. ~2400 V)

0.04 μA

75.3 mA

19

ELECTRIC MOTOR TEST

The extreme variation in parameters on the previous page indicates that the re-wound motor must have different specifications than the original one. The lower resistance shows that, either a larger diameter of copper wire was used with fewer turns in the coil, or there is not enough copper. In that case, the motor has less HP.

The leakage parameters are wide apart. Poor practices in applying the varnish are the only possible explanation for such high current leakage rates.

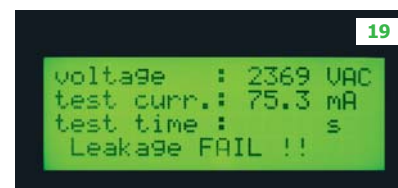

LEAKAGE TEST

20 When the compressor is subjected to pressure (20 bar nitrogen), leakages from one of the gaskets on the terminal plate are easily observable when the compressor is submerged in the water tank.



RUNNING TEST

The running test uses nitrogen and measures compressor displacement and valve plate performance:

○ Comparison Test	○ BITZER Standard Parameter	○ Compressor with Non-Original Parts
Displacement test	25 m ³ /h (±6%)	23.59 m ³ /h (more than 6% lower displacement)
Leak rate through discharge valve reeds	80 nl/h	151.55 nl/h



GREEN POINT IS EXPANDING CONTINUOUSLY WORLDWIDE. PLEASE CONTACT YOUR REGIONAL HEAD OFFICE FOR MORE INFORMATION.

1 FRANCE

**SRS BITZER – Green Point
Competence Centre**

2 Boulevard Jean Monnet, ZAC Parisud IV,
77380 Combs-la-Ville,

France

Tel +33 (0) 1 74 59 10 10

Fax +33 (0) 1 74 59 10 19

commercial@bybitzer.fr

2 USA

**BITZER Green Point –
USA Head Office**

4080 Enterprise Way
Flowery Branch, GA 30542

U.S.A.

Tel +1 770 718 2900

Fax +1 770 503 9226

customerservice@bitzerus.com

3 CHINA

**BITZER Refrigeration Technology
[China] Co., Ltd.**

No. 20, Fourth Jing Hai Road
Beijing Economic-Technological
Development Area

Beijing 100176

China

Tel +86 10 6781 9000

Fax +86 10 6781 9002

info@bitzer.cn

4 BRAZIL

BITZER Compressors Ltda.

Av. João Paulo Abilas, 777 – Jd. da Gloria
Cotia – SP CEP 06711-250

Brazil

Tel +55 (11) 46 17 91 00

Fax +55 (11) 46 17 91 28

atecnica@bitzer.com.br

5 SINGAPORE

Green Point Asia Pacific Pte. Ltd.

23 Neythal Road
#01-01D Block B

Singapore 628588

Tel +65 6267 4834

contact@bitzergreenpoint.com

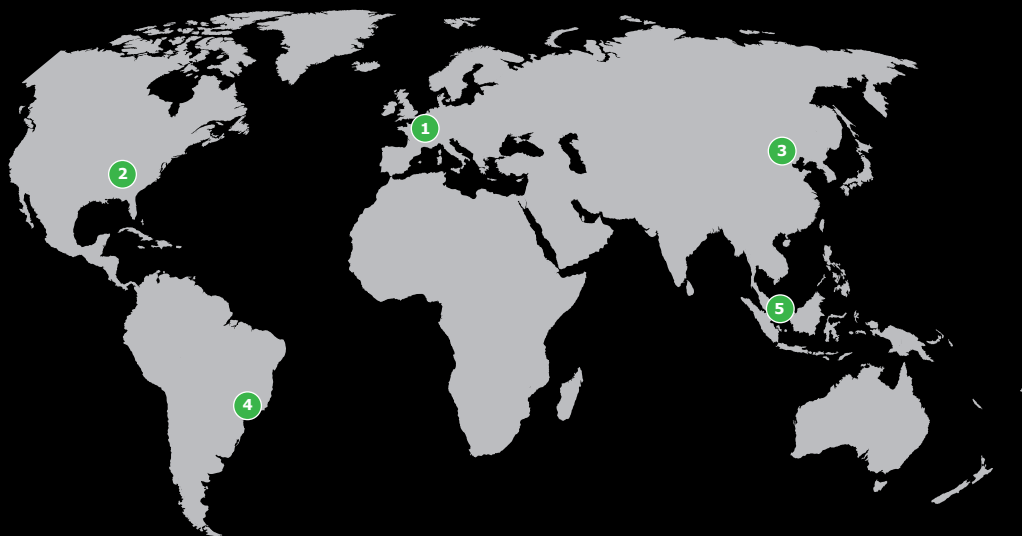

www.bitzergreenpoint.com

Subject to change // 10.2016